

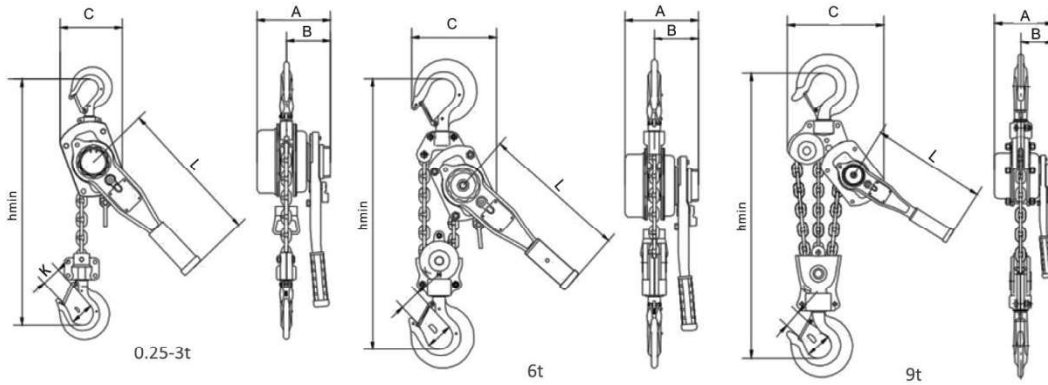

When Buying From Deso, You Are Buying More Than Products, You Are Buying Quality And Service

## LEVER BLOCK(X TYPE)

- ✓ Compact Design, Small Body, Low Headroom - Wide Usage
- ✓ Stronger Inner Structure, More Durable
- ✓ Wider Hooks With More Flexibility
- ✓ High Precision Machining Gears
- ✓ Impact Resistance Gear Cover
- ✓ Double Pawl Brake System, Fused Brake Disc
- ✓ High Precision Caged Roller Bearing
- ✓ Chain Stopper Protects The Body
- ✓ Calibrated G80 Chain For Heavy Duty Use
- ✓ Quenched And Tempered Hooks
- ✓ Over 1500 cycles EN 13157 Endurance Testing
- ✓ Individual Serial No. For Each Set, With Aluminium Sticker Showing Brand Deso, Capacity, Serial No.



CAPACITY (T)		0.25	0.5	0.75	1.5	3	6	9
LIFT (M)		1.5	1.5	1.5	1.5	1.5	1.5	1.5
TEST LOAD (kN)		3.1	6.3	11	22.5	45	90	135
PULL TO LIFT RATED LOAD(N)		237	283	320	380	480	600	740
H Min		160	200	180	380	450	500	550
STRANDS OF LOAD CHAIN		1	1	1	1	1	2	3
LOAD CHAIN DIA(MM)		4	5	6	8	10	10	10
DIMENSION (MM)	A	119	130	148	172	200	200	200
	B	79	83	90	98	115	115	115
	C	90.5	112	136	160	180	235	335
	D	31	36	40	52	60	68	85
	K	24	25.5	28	38	42	50	57
	L	168	178	250	300	375	375	375
NET WEIGHT (KG)		2.7	3.8	7.4	11.6	20	29.4	45
EXTRA WEIGHT OF ONE M LIFT(KG)		0.41	0.52	0.8	1.1	2.2	4.4	6.6
PACKING SIZE (CM)		21*13*10	23*14*14	37*16*15	48*17*15.	52*20*18	54*20*20	63*38*28